

MSA-650 IRIS Micro System Analyzer

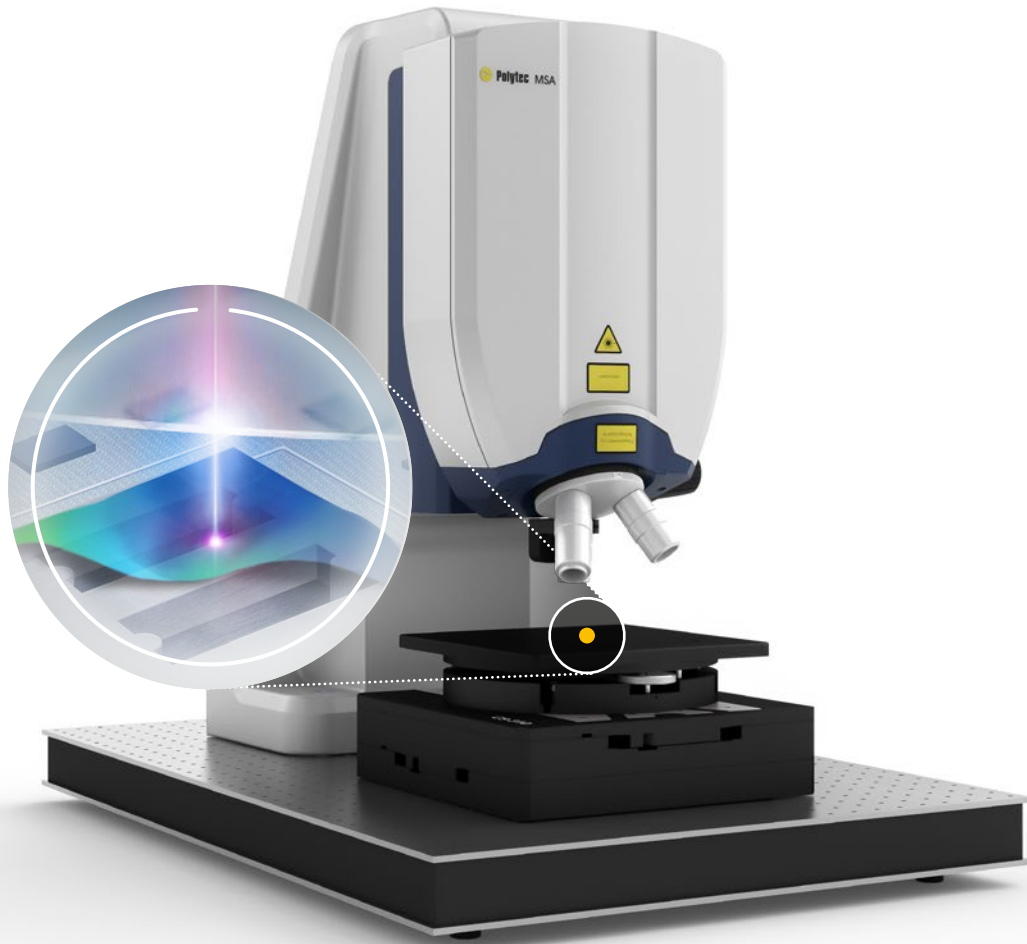

MSA-650 IRIS Micro System Analyzer

Optical characterization of dynamics

inside Si-capped MEMS

Product brochure





Highlights

- IR capability to measure MEMS dynamics through different layers of Si-capped devices
- Real-time out-of-plane response measurement up to 25 MHz (w/o post-processing)
- Sub-picometer out-of-plane displacement resolution
- Superior separation of the individual device layers
- Stroboscopic video microscope to measure in-plane motion up to 2.5 MHz
- Automated system that integrates well for production (probe station compatibility)

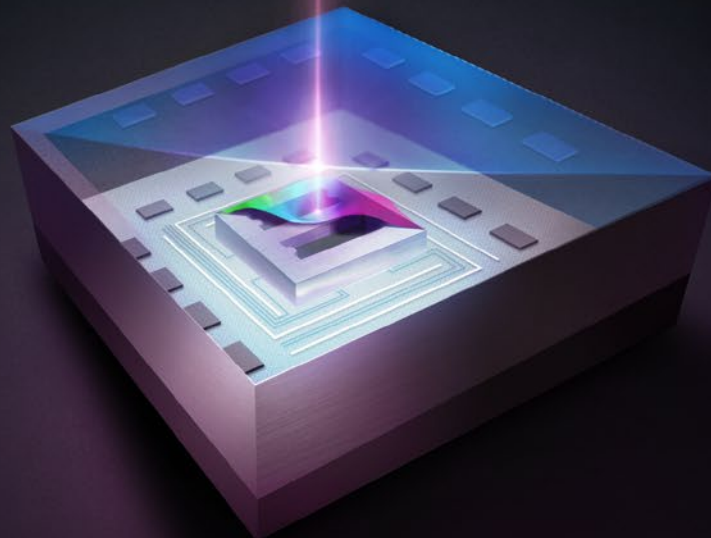

Optical characterization of dynamics inside Si-capped MEMS

Dynamic characterization of MEMS devices to measure and visualize mechanical response is important for product development, trouble shooting and FE model validation.

The MSA Micro System Analyzers from Polytec provide fast, accurate optical measurements of out-of-plane (OOP) and in-plane motion (IP). Until now, this has been limited to unpacked devices that are optically accessible. Now, the Polytec MSA-650 IRIS Micro System Analyzer allows even measuring through intact silicon caps on encapsulated microstructures like e.g. inertial sensors, MEMS micro-

phones, pressure sensors and more. The MSA-650 IRIS turn-key measurement solution comprises a controller, function generator with additional reference channels, powerful optical scanning software suite and optical sensor head with a sophisticated IR-optical design. With its dedicated IR camera and a low-coherence SLD source it is the premier full-field vibration measurement system to capture entire sample layers through silicon caps under operating conditions. This patented interferometer technology delivers excellent data quality due to superior separation of the individual device layers.

Probe station integration for wafer-level measurement



Wafer level testing requires the MSA measurement head to be combined with a probe station. Whether it's necessary to test devices prior to packaging or to perform routine quality control measurements directly on the wafer, the MSA-650 IRIS can be mounted onto virtually all commercially available wafer probe stations.

Wafer-level production quality control

While electrical test procedures are standard, optical measurements using the MSA-650 IRIS provide direct mechanical response of how the devices actual perform. The MSA-650 IRIS can be combined with a semi-automatic probe station to efficiently and quickly measure

the dynamic behavior of all MEMS devices right on a wafer. That way, you can achieve a high throughput and have a key tool for monitoring the production process. Wafer-level testing prior to chip separation allows the sorting out of bad dies early in the production process. This helps to keep MEMS production costs low while maintaining high yield and quality levels.

For example, the thickness of pressure sensor membranes can be determined by analyzing the membrane's frequency spectrum. Another example is the measurement of stress which affects the lifetime of the MEMS device, thereby allowing the qualification of the expected service life.

For encapsulated MEMS – modal testing and optical vibration measurement

Laser Doppler vibrometry (LDV) is a well-established technique to study the mechanical dynamics of MEMS with utmost precision. Most laser vibrometers work at visible wavelengths for which the silicon encapsulation is opaque and inhibits MEMS inspection. Thus, LDV testing of such MEMS via visible wavelengths requires either un-encapsulated MEMS or decapping the device.

However, the step of MEMS capping in fabrication processes may result in additional stress, which might alter the device performance. Therefore, a comprehensive characterization of the MEMS device in its final and encapsulated state is indispensable.

As silicon is transparent in the near infrared spectrum above wavelengths of 1050 nm, the underlying technology of infrared-interferometer-based vibration measurement opens up the possibility for inspecting of encapsulated MEMS for authentic and most representative analysis results. Polytec's brand new, patented state-of-the-art interferometer technology now delivers supreme data quality due to superior separation of individual device layers in the si-capped MEMS devices.

With a dedicated SWIR camera and a low-coherence SLD source the MSA-650 IRIS is the worldwide first measurement system with this patented technology to visualize the si-encapsulated devices, measure in-plane vibration with down to 30 nm resolution and real-time out-of-plane vibrations up to 25 MHz with picometer resolution and below.

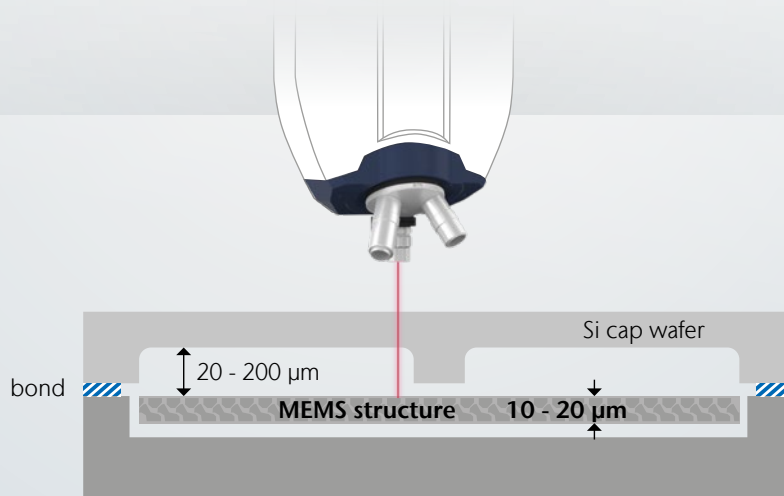

Use the leading technology in vibration analysis

In order to use Laser Doppler vibrometry (LDV) for a look into encapsulated MEMS, it is necessary to study the optical properties of silicon. While silicon is opaque for visible light, it shows a good transmission in the near- infrared range starting at around 1050 nm. A limitation for transmission however, is the high refractive index of around 3.4 at 1550 nm leading to considerable Fresnel reflections at boundary interfaces. Under the assumption that the MEMS is structured with one silicon cap above the relevant MEMS surface and the interfaces show no scattering, only around 7% of the probe beam will be available in the end as signal light from the surface under test.

This attenuation effect alone is no problem for Laser Doppler Vibrometry (LDV) measurements. However, the reflections from the static surfaces above and below the relevant MEMS surface cannot be ignored. Due to the narrow distances in the range of tens of micrometers inside the device, it is quite likely, that this residual unwanted part of the probe light is also collected by the interferometer. The residual light will thus interfere with reference light on the detector and alter the measurement results. This affects the amplitude accuracy and leads to spurious lines in the frequency spectra.

All methods and products presented so far rely exclusively on confocal suppression of unwanted reflections. This approach only works with the assumption of unrealistically large distances between the surfaces inside the MEMS.

Our patented approach uses short coherent light to improve accuracy. In contrast to laser light, low coherent light from a superluminescence diode only interferes if the light paths in the interferometer are balanced within the coherence length of the source. Thereby excluding light from outside the focus. This principle is utilized in white- light interferometers or for optical coherence tomography and now for the first time in the Laser Doppler Vibrometry (LDV). Enabling scanning LDV measurements with 25 MHz bandwidth and with an amplitude resolution of 100 fm/ $\sqrt{\text{Hz}}$ on encapsulated MEMS.

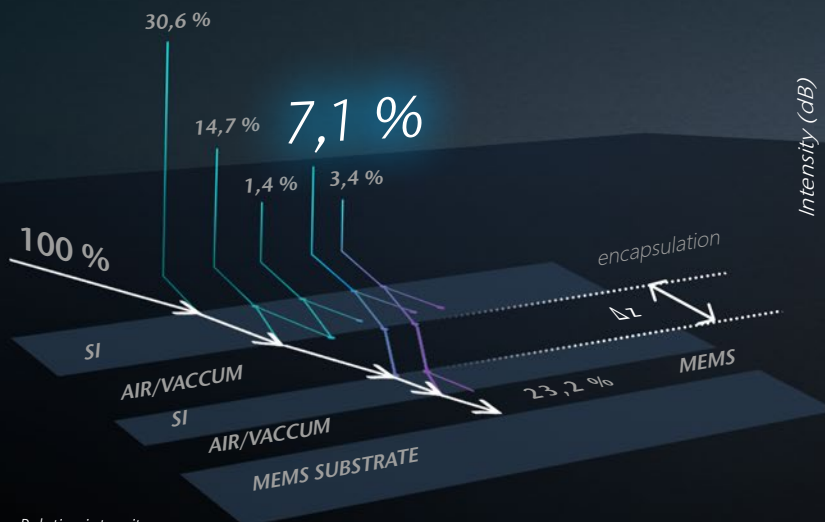

Relative intensity contribution of reflections from different surfaces

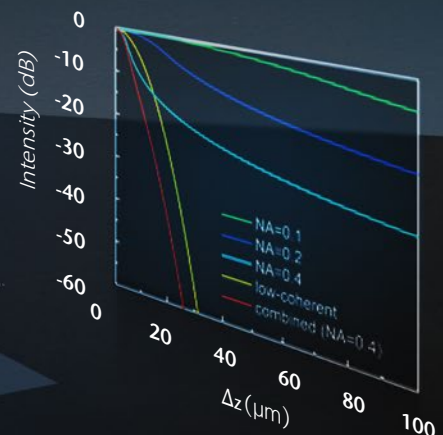

Out of focus light intensity over distance of reflection origin for different optical configurations

Real-time vibration analysis

Scanning laser Doppler vibrometry (SLDV) provides non-contact, real-time measurements of velocity and displacement on a grid of selected measurement points. This allows characterization of out-of-plane vibrational behavior of a dedicated layer inside a si-capped device. Unique features include the ability to acquire data with (sub-)picometer displacement resolution, to capture frequency response up to 25 MHz, and to analyze non-linear systems.

How it works

The laser Doppler vibrometer (LDV) is a precision optical transducer for measuring the vibration velocity and displacement at a measurement point. It works by sensing the frequency and phase shift of back scattered light from a moving surface. The object scatters or reflects light from the laser beam and the Doppler frequency shift is used to measure the component of velocity which lies along the axis of the laser beam. In contrast to laser light, low coherent light from a superluminescence diode only interferes if the light paths in the interferometer are balanced within the coherence length of the source. Thereby excluding light from outside the focus.

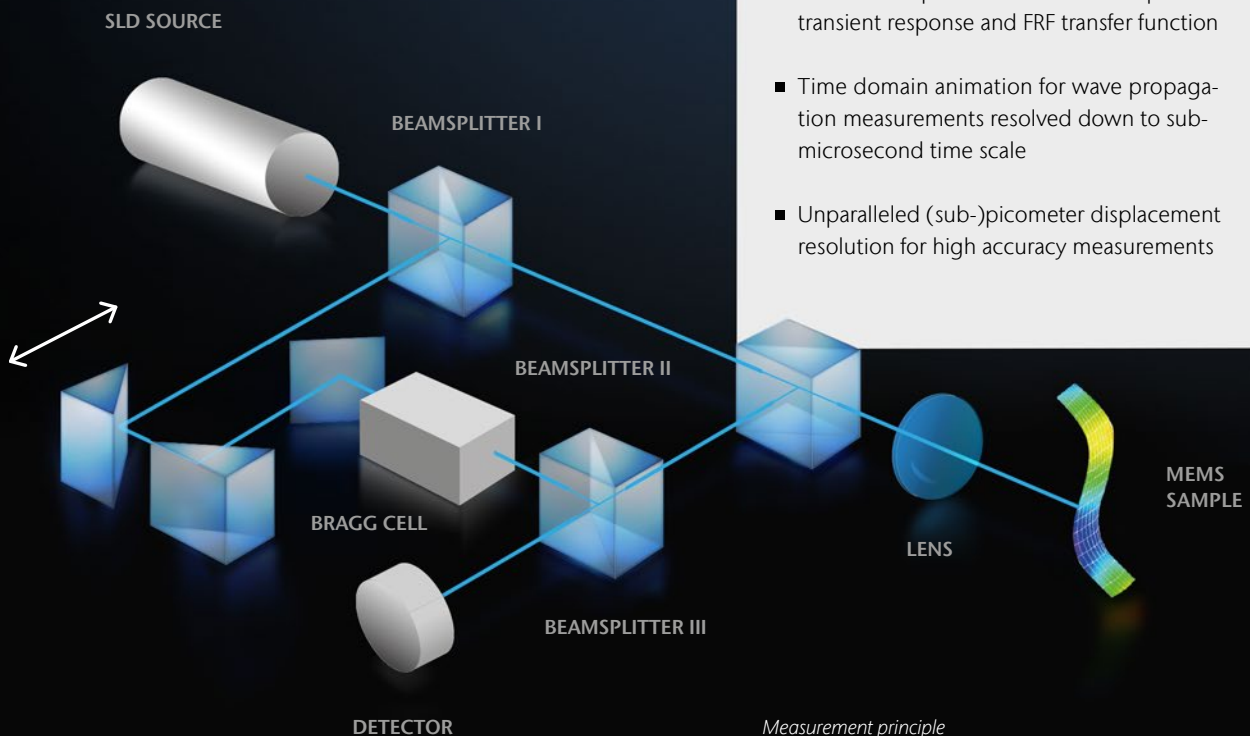

Highlights

- Dynamic response (vibration) measurement of velocity and/or displacement
- Direct view into si-encapsulated devices facilitates the targeted location and measurement of the relevant surface
- Full-field vibration mapping and broadband, out-of-plane frequency response information for intuitive results
- Real-time response measurement captures transient response and FRF transfer function
- Time domain animation for wave propagation measurements resolved down to sub-microsecond time scale
- Unparalleled (sub-)picometer displacement resolution for high accuracy measurements

Measurement principle and optical setup of laser Doppler vibrometry (LDV)

Intuitive and powerful data analysis and evaluation

Our built in signal analysis software provides frequency response over the entire frequency bandwidth without the need to know the resonance frequencies in advance. The intuitive software package provides a built in signal generator to drive the device using a wide range of excitation wave forms, and the ability to analyze time domain, FFT, Zoom FFT, averaged and peak hold data. Operational deflection shapes (ODS) are visualized as impressive full field, 3D animations from the frequency response function (FRF) data. An open programming interface, versatile data export and a powerful built-in signal processor provides enhanced post-processing capabilities.

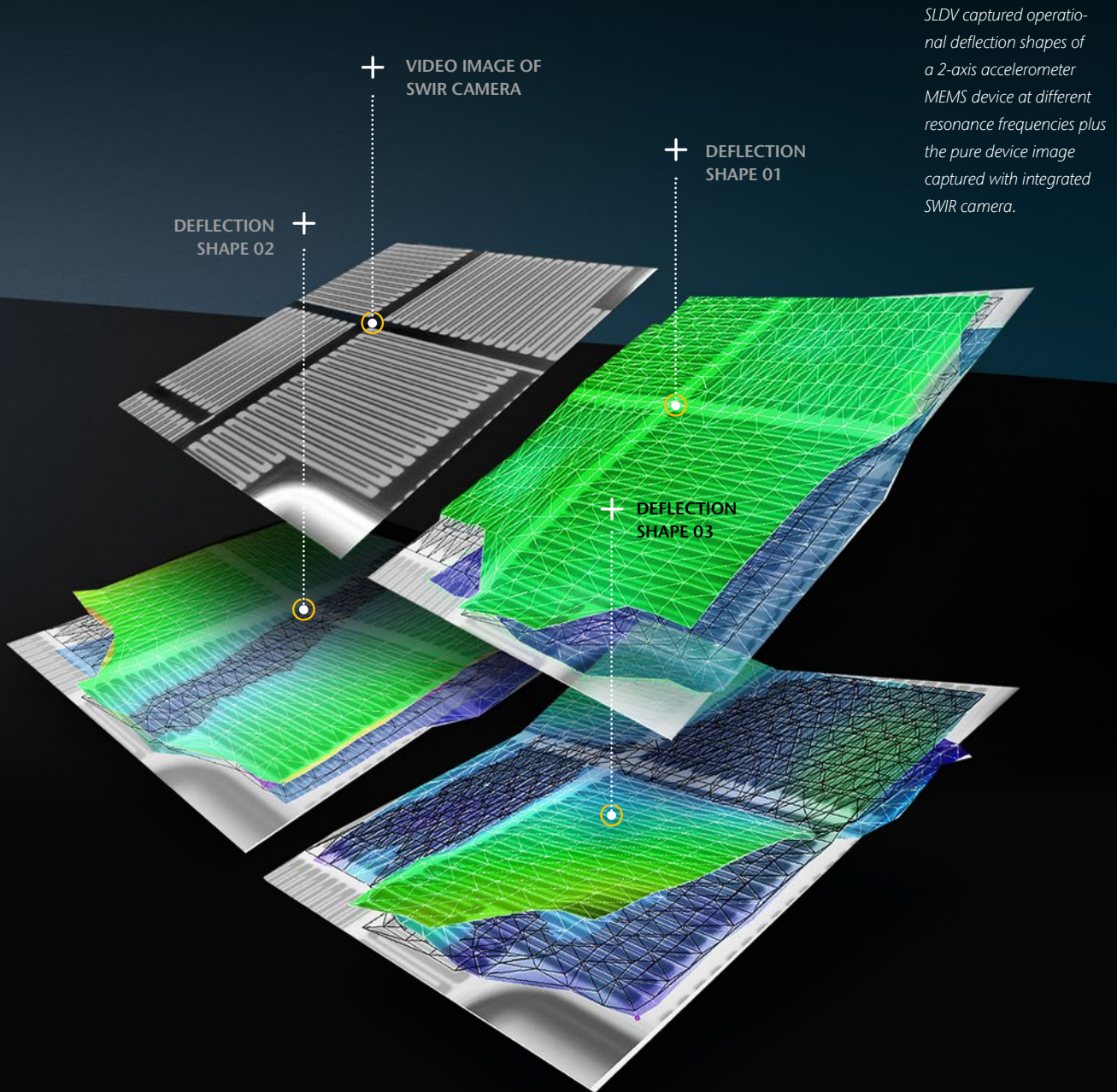

SLDV captured operational deflection shapes of a 2-axis accelerometer MEMS device at different resonance frequencies plus the pure device image captured with integrated SWIR camera.

Planar motion analysis

Stroboscopic video microscopy provides a powerful method for the measurement and true motion visualization of the in-plane dynamics of microstructures. To precisely measure the planar motion of the device under test, a combination of stroboscopic SWIR illumination, digital imaging and pattern tracking is applied. Thus motions of fast moving objects can be sharply frozen in time to capture and track the exact position of a region of interest (ROI) on the specimen.

How it works

Stroboscopic video microscopy for in-plane motion detection employs a special kind of stroboscopic technique: short SWIR light pulses synchronized with the objects motion capture the position at precise instants of time (phase angles). During the illumination time the motion is frozen. By shifting the timing of these

pulses by set increments, the motion of a moving object can be sampled and reconstructed. This procedure guarantees a high degree of measurement accuracy and a visual real-time analysis in live mode. The system is set to operate on predefined frequency bands selected from out-of-plane vibration measurements.

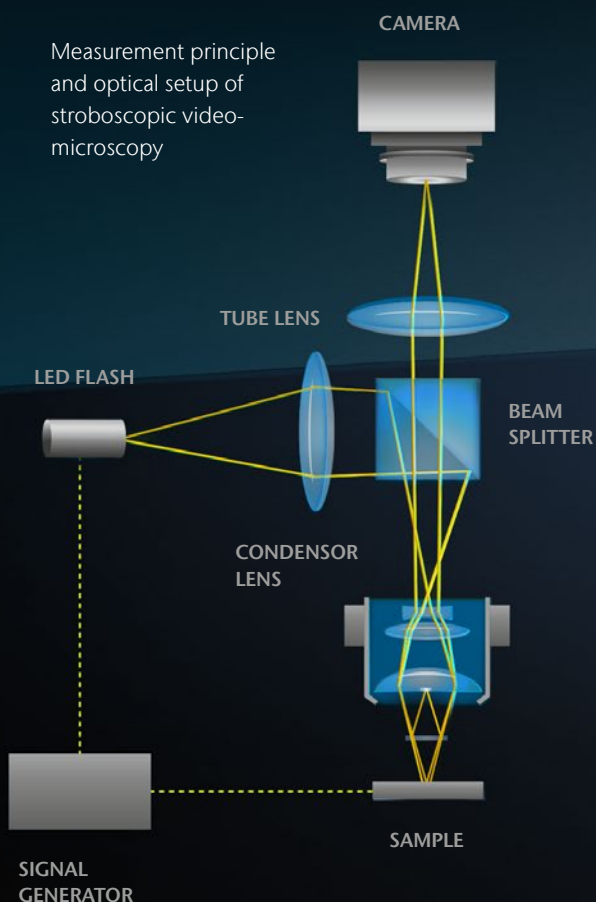

Highlights

- Easily measure and visualize in-plane motions with high grade SWIR microscope setup
- Extract displacement amplitudes, system resonances, transient responses, phase variations and more
- True motion video shows real behavior of the structure
- Integration with laser Doppler vibrometry for rapid identification of resonances and band data transfer
- 30 nm displacement resolution, bandwidth up to 2.5 MHz, multi-band measurement
- Differential measurement comparing different areas of interest

Laser Doppler vibrometry combined with in-plane stroboscopy

The combination of two complementary measurement techniques to investigate the vibrational behavior of small structures provides superior performance. The highly sensitive laser Doppler technique can rapidly find all in-plane and out-of-plane resonances from broadband excitation. In a second step, the stroboscopic video microscopy technique is used to obtain accurate amplitude and phase information of in-plane resonances identified by laser vibrometry. Unknown resonance peaks can be found in a broadband frequency response spectrum without a time consuming search.

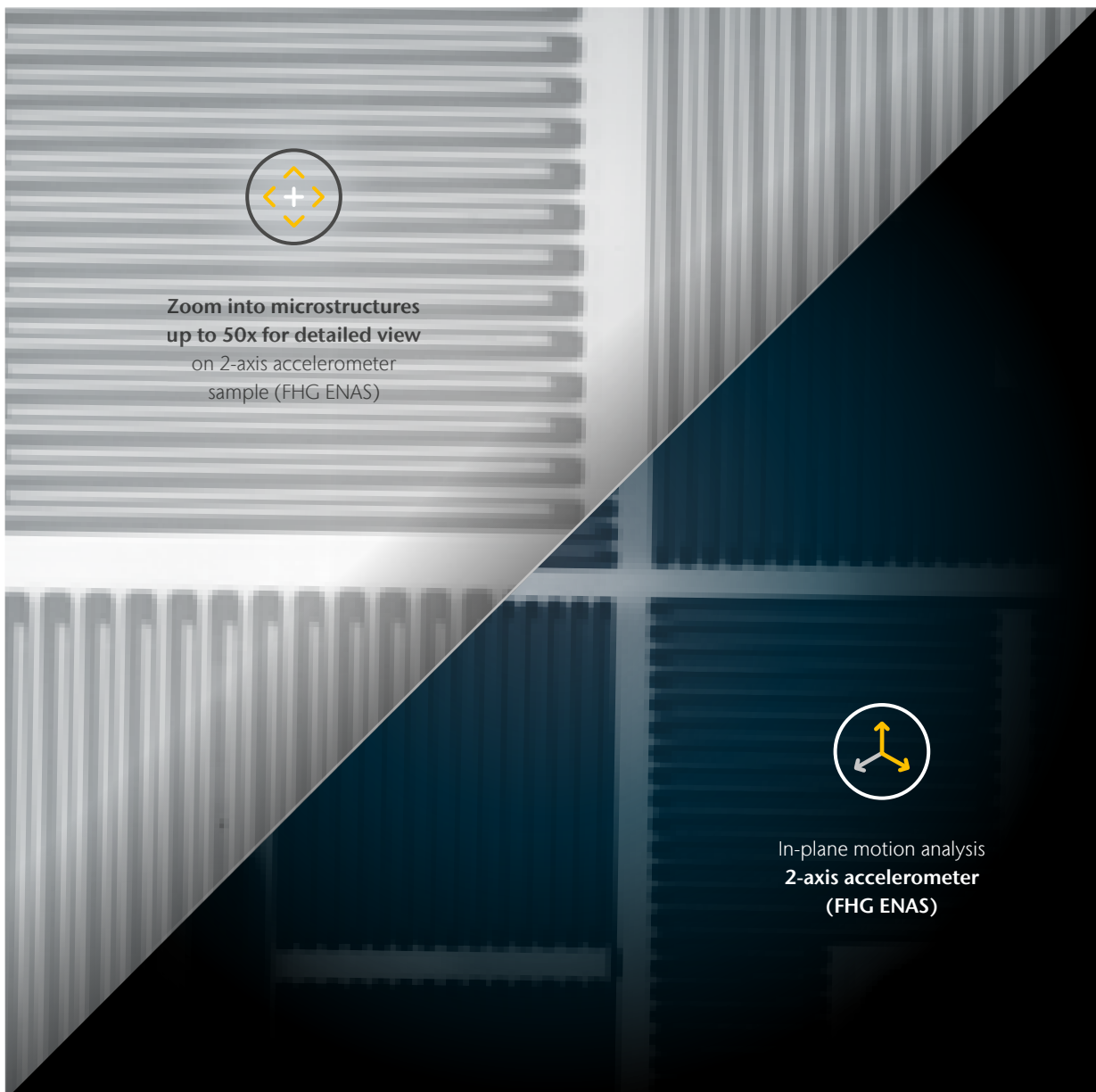

The system and its parts

- 1 Portal stand
- 2 Sensor head
- 3 XY positioning stage
- 4 Analysis software
- 5 Front-end with function generator and data management system (DMS)



Accessories tailored to your needs

Application-specific stand solutions

The MSA-I-650 IRIS Sensor Head can be mounted on Polytec test stands or commercially available probe stations. Polytec offers both manual and automatic focus versions of the test stand with integrated z stages. Polytec stands are available with vibration isolated workstations or can be installed on user supplied optical tables.

Automated sample positioning and measurement

Objects that are larger than the field of view can be measured. An automated xy translation stage enables sequential measurements that are stitched together to create a larger field of view as in a single data set.

Please refer to the MSA-650 IRIS datasheet and to the accessory datasheet for stand-based systems for detailed technical specifications of the MSA-650 IRIS accessories.



XY positioning stage with tip-tilt unit for fine-adjustment of samples

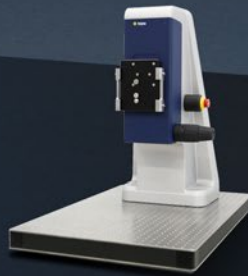

Base stand with manual z-axis on breadboard



Portal stand with motorized z-axis for supporting and focusing the sensor head



Wafer Prober Module for testing at wafer level



Air-damped vibration isolation table with active level adjustment



Electronically controlled voice coil stabilization for highest isolation performance

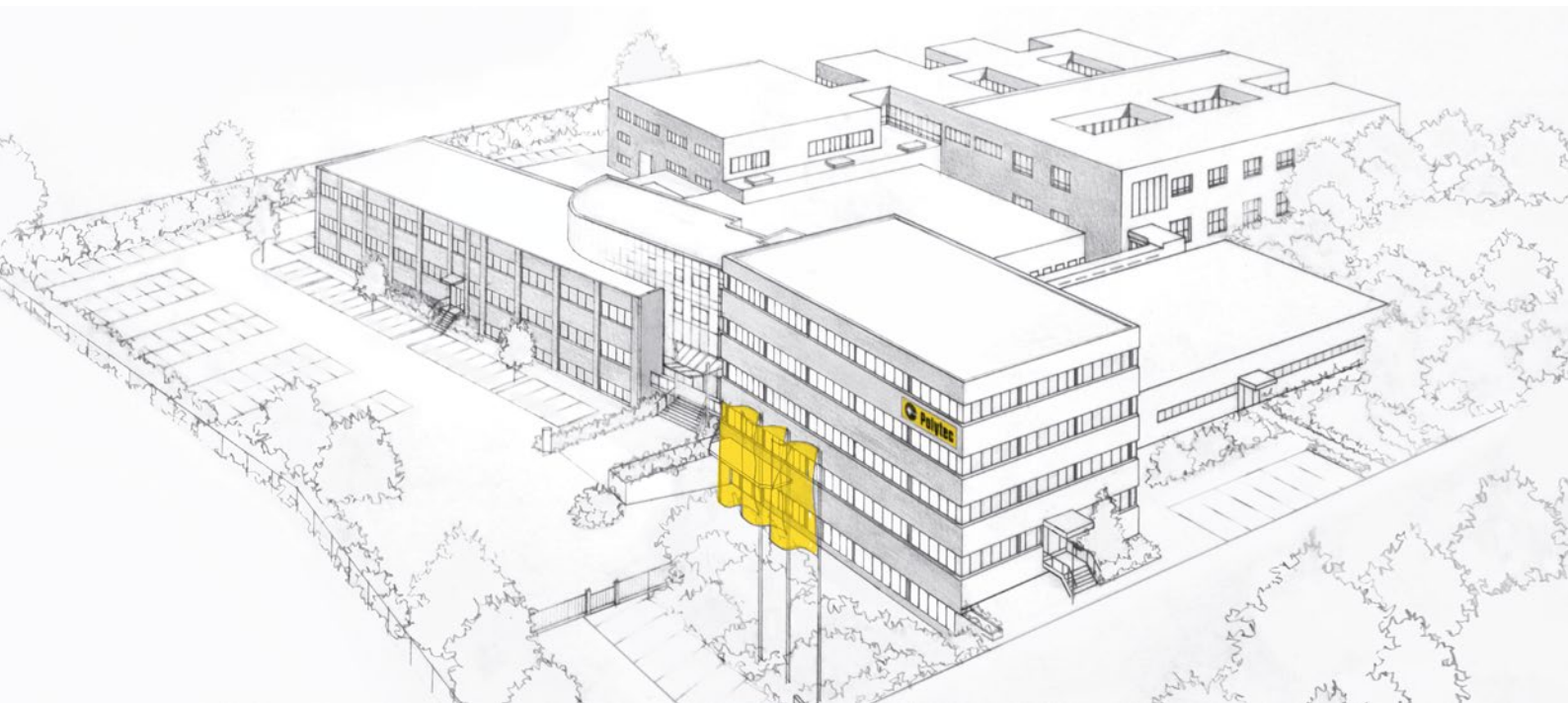

Shaping the future since 1967

High tech for research and industry.
Pioneers. Innovators. Perfectionists.

Find your Polytec representative:
www.polytec.com/contact

Polytec GmbH · Germany
Polytec-Platz 1-7 · 76337 Waldbronn