

POLYTEC GmbH Büro Berlin Schwarzschildstraße 1 D - 12489 Berlin GERMANY
Tel: +49 (30) 63 92 51 40 Fax: +49 (30) 63 92 51 41 wl@polytec.de www.polytec.de

MODEL ML SERIES ACOUSTO-OPTIC MODE LOCKER

- CHOICE OF WINDOW CONFIGURATION
- USER SPECIFIED FREQUENCY
- CHOICE OF MODE SPACING
- HIGH EFFICIENCY
- WIDE RF BANDWIDTH
- TEMPERATURE TUNING

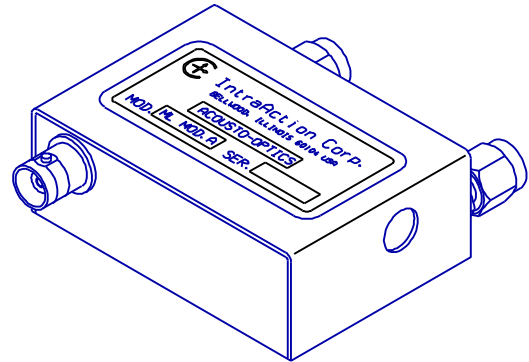

DESCRIPTION

The ML series Mode Lockers are manufactured from high quality fused silica acousto-optic material. The RF sound field is generated with Lithium Niobate transducers. The user can specify window configuration, operating frequency, and mode spacing in order to optimize system performance.

The Mode Locker is an acoustic standing-wave device with resonant mode spacing determined by the thickness of the acousto-optic material. When an integral number of acoustic half wavelengths are present across the material, standing waves are formed and modulate the laser cavity at twice the applied RF frequency. The C/2L frequency of the laser cavity should be set to the Mode Locker modulation frequency. Standard acoustic RF frequencies are from 20 to 70 MHz with higher frequencies available upon request.

Water flow through the Mode Locker is used to stabilize the mode resonant frequency when used in the CW operating mode and may not be required for low duty cycle pulse operation. The frequency of the resonant mode peak can be temperature tuned +7 kHz / °C by changing the temperature of the Mode Locker.

A variety of window configurations have been found to be most useful and are tabulated below. For optimum performance, optical polarization should be parallel to the housing mounting surface.

SPECIFICATIONS

MODEL ML- * * 3() 1

Optical Antireflection (AR) Coating ¹	1064 nm
Choice of Acoustic RF Frequency (* *) ²	20 MHz to 70 MHz
Mode Spacing	330 kHz or 460 kHz
RF Bandwidth	+/- 10 percent of center frequency
Active Optical Aperture ³	3 H x 5 W mm
Diffraction Efficiency	50 percent
RF drive power	2 watts
Temperature Tuning	+7 kHz / °C
Static Optical Insertion Loss	0.3 percent

<u>Window Description</u>	<u>Designation ()</u>	<u>Mode Spacing</u>
4° Wedge	A	460 kHz
2° Rhomboid	B	460 kHz
1° Wedge	C	460 kHz
Brewster	D	460 kHz
1° Wedge	J	330 kHz
Brewster	Q	330 kHz

¹ Non-Brewster window devices are AR coated with a high damage threshold coating for 1064 nm; other wavelengths are available. Designator 1 in the model number is for the AR coating at 1064 nm. This designator will be different for other AR coatings.

² Frequency * * can be specified up to and above 100 MHz.

³ Active optical apertures of 4 x 5 and 5 x 5 mm can also be specified. Change designator 3 to either 4 or 5.

ENG210B

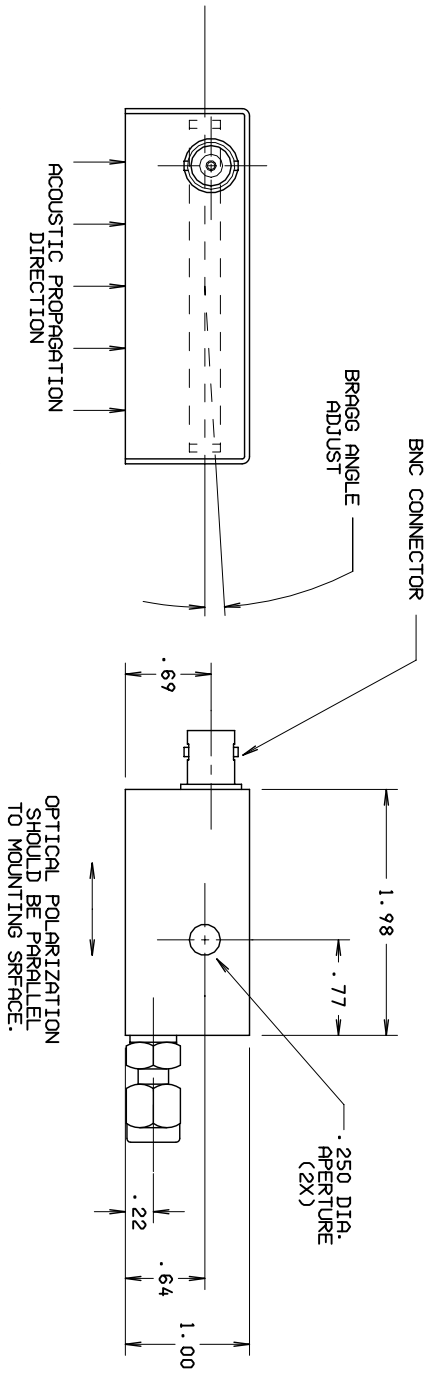

REVISIONS		
ISSUE	DESCRIPTION	APPD./DATE
ORIGINAL	JM 1-7-84	JL
A	REDRAN ONTO CAD SYSTEM, ECH#1069 GJK 7-27-91	JL

ALL REVISIONS TO THIS DRAWING MUST BE MADE ON THE CAD SYSTEM

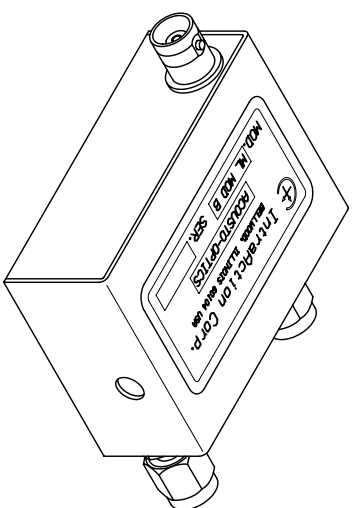
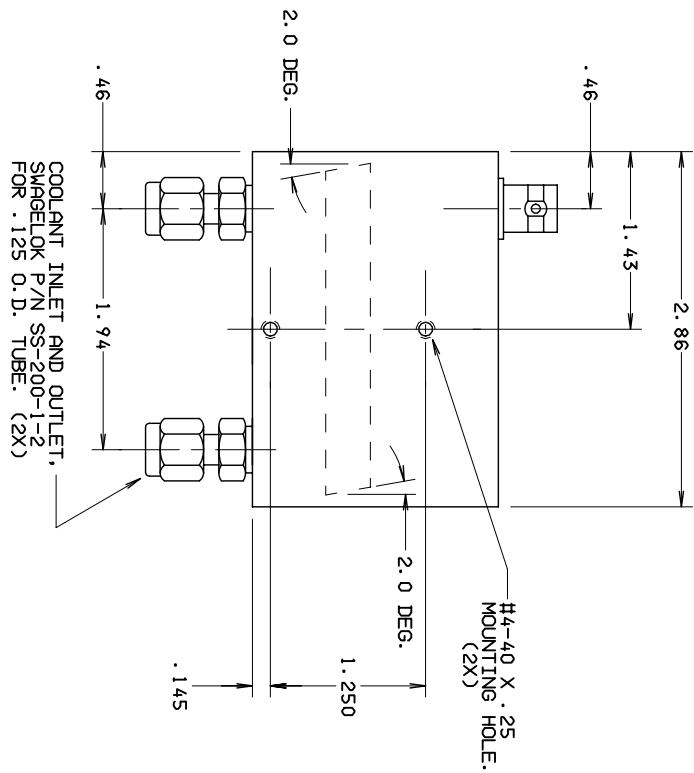

UNLESS OTHERWISE SPECIFIED TOLERANCES AND DIMENSIONS ARE IN INCHES		APPROVED DATE	<p>IntraAction Corp. 3719 WARREN AVE. BELLWOOD, IL 60104</p> <p>PHONE (708) 547-6644</p>
LINEAR : .XX ± .010 ANGULAR ± / DIAMETERS ± / LIMITS APPLY BEFORE FINISHING DO NOT SCALE THIS PRINT		CHECKED DATE	
MATERIAL		DATE	TITLE
MFG. INSTR.		1-7-84	MODE LOCKER (MODEL B) OUTLINE
D. C. INSTR.		FINISH	FSCM NO.
SCALE FULL		UNIT WEIGHT	DMG. NO.
SHEET 1 OF 1			B 102027
			ISSUE A