

PPM-30 PON Power Meter

World Most Powerful Integrated PON Tester



PPM-30 PON Power Meter can perform in-service testing of all PON signals (1310/1490/1550nm) on any spot of the network featuring pass-through design, burst mode and Pass/Warning/Fail assessment function, which can greatly help you evaluate PON signals transmission quality.

Features

- ◆ Specially designed for PON applications
- ◆ Easy operation: Connect and get results
- ◆ Simultaneous Triple-play PON signals measurement
- ◆ Pass-through test: Applicable anywhere on PON
- ◆ Burst mode 1310nm upstream signal detection
- ◆ User-defined thresholds (with PPM Manager Software)
- ◆ Pass/Warning/Fail assessment
- ◆ Optional Visible Fault Locator for macro bend detection and fiber identification
- ◆ Optional Stabilized Laser Source and SM/MM Power Meter

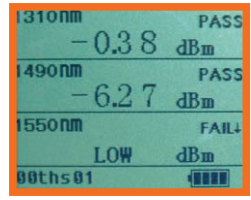

Simultaneous Measurement of All PON Signals

High quality built-in filter for Triple-play signals (1310/1490/1550nm) measurement



Flexible Measurement on PON

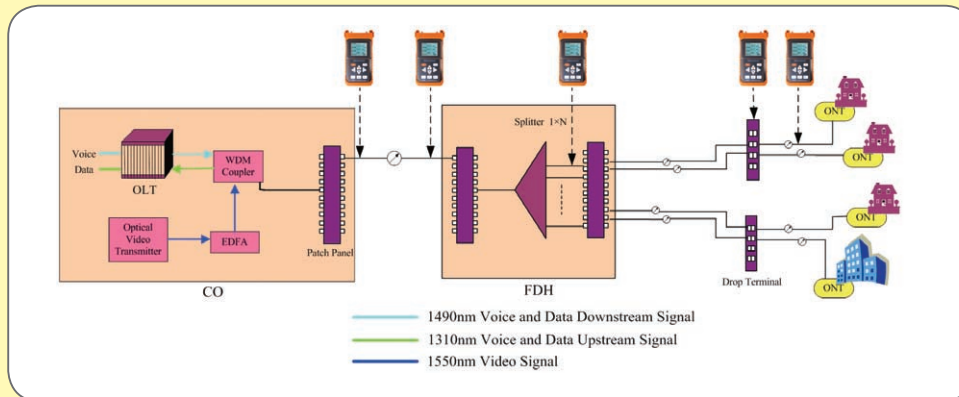

Pass-through Simultaneous Measurement & Display of All PON Signals

PPM-30 works as a pass-through device, which can be connected anywhere between OLT and ONU.

A small percentage of optical signals are extracted for use by PPM-30 detectors. This approach enables all wavelengths to be used simultaneously and introduces no interruption to network services.

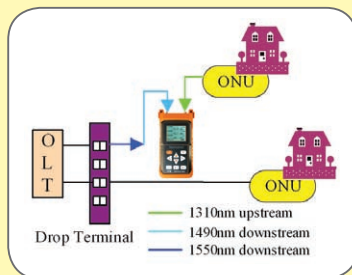

1310nm	PASS
-3.15	dBm
1490nm	WRNG
-20.76	dBm
1550nm	PASS
-3.29	dBm
00fddd1	

- ◆ Pass-through connection and simultaneous measurement of all PON signals
- ◆ Filtered detectors for individual signal measurement at each wavelength
- ◆ Upstream signal burst mode detection at 1310nm

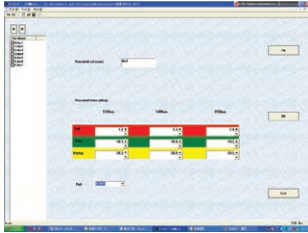

User-defined Threshold Sets

PPM-30 enables threshold setting - each set consists of three wavelengths (1310, 1490 and 1550nm) with their own Pass, Warning and Fail thresholds. These values can be configured for easy assessment of fibers, components and test points on network.

Optional Stabilized Laser Source and Optical Power Meter

These two options enable PPM-30 to evaluate fiber link loss condition during network installation.



Ordering Information

PPM-30XXX

V: Visible Fault Locator
 P: Optical Power Meter
 S: Stabilized Laser Source

Model
 PPM-30
 PPM-30V
 PPM-30P
 PPM-30S
 PPM-30VP
 PPM-30PS

Specifications

Model	PPM-30		
Calibrated Wavelength	1310nm	1490nm	1550nm
Measurement Range (dBm)	-40 ~ +10 ⁽¹⁾	-40 ~ +12	-40 ~ +20
Spectral Passband (nm)	1310 ± 50	1490 ± 15	1550 ± 10
Power Uncertainty (dB)	≤0.5		
Accuracy (dB)	0.01		
Insertion Loss (dB)	≤1.5		
Visible Fault Locator (Optional)			
Output Power (dBm)	≥-3		
Max Measurement Range	5 Km		
Optical Power Meter (Optional)			
Calibrated Wavelength (nm)	850,1300,1310,1490,1550,1625		
Power Range (dBm) ⁽²⁾	-70 ~ +10		
Detector Type	InGaAs		
Accuracy	± 5% ± 0.01nW (± 0.5dB@850nm)		
MOD Identification	270, 1K, 2K Hz		
Stabilized Laser Source (Optional)			
Wavelength (± 20nm)	1310, 1490, 1550nm		
Output Mode	CW, 270Hz, 1KHz, 2KHz		
Spectrum Width (nm)	≤5		
Output Power (dBm)	≥-3		
Output Power Display	Yes		
General Specifications			
Backlight Display	Yes		
Connector	FC/PC (Interchangeable SC, ST)		
Data Storage	>2000 records		
Data Interface	USB		
Power Supply	NiMH Battery (1600mAh, 9.6V) / AC Adapter		
Battery Life	≥35 hours		
Relative Humidity	0 to 95% (non-condensing)		
Weight	750g (1.6 lbs)		
Dimensions (HxWxT)	196x100x44mm (7.7x3.9x1.7inch)		

Note: (1) Burst mode measurement range at 1310 nm: -30 ~ +10dBm

(2) The lower limit of measurement range at 850nm is -60 dBm

* Specifications Subject to change without notice

